



ACCUSTOR



HARDWARE DETAILED USER'S MANUAL v1.0

Copyright ©2012

This guide and any accompanying software and firmware are copyrighted. No parts of this publication may be reproduced, stored on a retrieval system, or transmitted, in any form or by any means, electronic, mechanical, photocopy, recording, or otherwise, without prior written consent except for copies retained by the purchaser for backup purposes.

All rights Reserved- Printed in Taiwan.

Notice

We make no warranties with respect to this documentation either express or implied and provide it "as it". This includes but is not limited to any implied warranties of merchantability and fitness for a particular purpose. The information in this document is subject to change without notice. We assume no responsibility for any errors that may appear in this document.

The manufacturer shall not be liable for any damage, or for the loss of information resulting from the performance or use of the information contained herein

Trademarks

Product names used herein are for identification purposes only and may be the trademarks of their respective companies. All trademarks or registered trademarks are properties of their respective owners.

Regulatory information

For Europe

This drive is in conformity with the EMC directive.

Federal Communications Commission (FCC) Statement

This equipment has been tested and found to comply with the limits for a Class A digital device, pursuant to part 15 of the FCC Rules.

Those limits are designed to provide reasonable protection against harmful interference in a residential installation. This equipment generates, uses and can radiate radio frequency energy and, if not installed and used in accordance with the instructions, may cause harmful interference to radio communications. However, there is no guarantee that interference will not occur in a particular installation. If this equipment does cause harmful interference to radio or television reception, which can be determined by turning the equipment off and on, the user is encouraged to try to correct the interference by one or more of the following measures:

Reorient or relocate the receiving antennas.

Increase the separation between the equipment and receiver.

Connect the equipment into an outlet on a circuit different from that to which the receiver is connected.

Consult the dealer or an experienced radio/TV technician for help.

Warning:

A shielded-type power cord is required in order to meet FCC emission limits and also to prevent interference to the nearby radio and television reception. It is essential that only the supplied power cord be used.

Use only shielded cables to connect I/O devices to this equipment.

You are cautioned that changes or modifications not expressly approved by the party responsible for compliance could void your authority to operate the equipment.

About This Installation Guide

Welcome to Hardware Installation Guide. This guide is designed to be used as step-by-step instructions for installation of your subsystem, and covers everything you need to know in learning how to operation, troubleshooting and future upgrades. For the detail about how to configure your subsystem, please refer to the Software Operation manual.

Symbols in Text

These symbols may be found in the text of this guide. They have the following meanings.



Caution

Caution

This icons indicates that failure to follow directions could result in personal injury, damage to your equipment or loss of information.



NOTE

Note

This icon presents commentary, sidelights, or interesting points of information .

Important terms, commands and programs are put in **Boldface** font.

Screen text is given in **screen** font.

Contents

ABOUT THIS INSTALLATION GUIDE	IV
SYMBOLS IN TEXT.....	IV
CONTENTS.....	V
CHAPTER 1. INTRODUCTION	1
MODEL VARIATIONS	1
FEATURES	1
UNDERSTANDING THE ACCUSTOR RAID SUBSYSTEM.....	2
<i>Front Panel Overview</i>	2
<i>Rear Panel Overview</i>	4
CHAPTER 2. INSTALLATION.....	8
UNPACKING & CHECKING THE EQUIPMENT.....	8
WHAT ELSE YOU NEED	8
ESD PRECAUTION.....	9
INSTALLING HARD DISKS	9
INSTALL THE ACCUSTOR JBOD SUBSYSTEM IN A RACK.....	10
SYSTEM CONNECTION.....	12
CONNECTION TO THE RAID SYSTEM (BASIC).....	13
CONNECTION TO THE RAID SYSTEM WITH MORE SAS JBODS.....	14
TURNING ON FOR THE FIRST TIME.....	15
TURNING OFF	15
CHAPTER 3. TROUBLE SHOOTING	16
REPLACE THE EXPANDER BOX	16
HOT SWAPPING TO REPLACE THE FAN MODULE.....	17
HOT SWAPPING TO REPLACE THE POWER MODULE.....	18
APPENDIX A. CONNECTORS	20
APPENDIX B. FIRMWARE UPDATING	21
APPENDIX C.	23
COMMAND LINE INTERFACE (CLI).....	23
CREATE A CLI CONNECTION	23
CLI COMMAND SET	23
APPENDIX D. SPECIFICATIONS.....	34

Chapter 1. INTRODUCTION

This chapter introduces the features and capabilities of AccuSTOR SAS to SAS/SATA JBOD subsystems.

You will find:

- ⇒ A full introduction to your JBOD SYSTEM
- ⇒ Details of key features and supplied accessories
- ⇒ A checklist of package contents
- ⇒ A checklist of what else you need to start installation

Model Variations

There are three available models in AccuSTOR JBOD subsystem series; which utilize Single 6Gbps miniSAS as Host interface and dual 6Gbps miniSAS connector for expansion, each with 12, 16, or 24 device bays.

<i>Model Name</i>	<i>Host Interface</i>	<i>Device bays</i>	<i>Controller Numbers</i>
AS424X6S AS424X6R	SAS (miniSAS)	24 bays	1 or 2
AS316X6S AS316X6R	SAS (miniSAS)	16 bays	1 or 2
AS212X6S AS212X6R	SAS (miniSAS)	12 bays	1 or 2

Features

The JBOD SYSTEM is designed to meet today's large volume and excellent performance storage requirements in rapidly changing business environment. It provides a maximum data protection and exceptional performance in a storage subsystem. Target usage ranges are set from small business to departmental and corporate server needs. The JBOD SYSTEM is designed for easy integration, smooth data expansion and server migration.

The JBOD SYSTEM supports the following features:





- Supports 6Gb SAS/SATA disk drives.
- Single or Dual 4x wide-port SAS connectors for host connection.
- Single or Dual 4x wide-port SAS connectors for expander module daisy chain.
- Redundant and Hot Swappable Fan, Power and Drives.
- Completely monitored by In-band SES.
- Configuration and environmental information is accessible either via the Serial Port or RAID System.
- Load sharing, hot swappable redundant power system with PFC function.

Understanding the AccuSTOR RAID subsystem

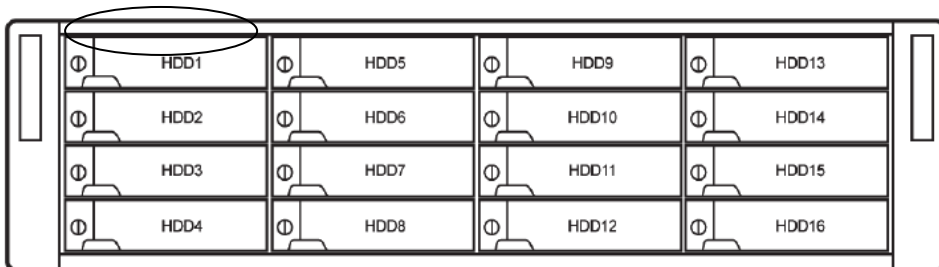
Front Panel Overview

LED Indicators Location



1.  Power On Indicator (Blue).
2.  Host System Access Indicator (Blue + blink).
3.  Power Fail Indicator (Red)
4.  Fan Fail Indicator (Yellow)
5.  Over Temperature Indicator (Yellow)

Driver Bay numbering convention

The enclosure bay numbering convention is shown in following figure. A bay is designed to house a single 1.0-inch high, 3,5-inch hard disk drive in his carrier module.

AS424X6R / AS424X6S

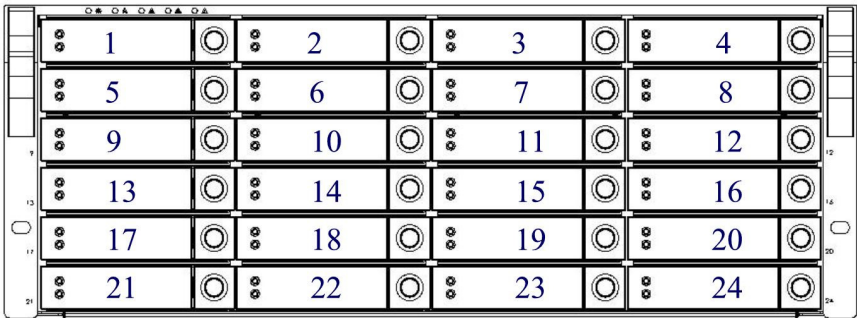

AS316X6R / AS316X6S

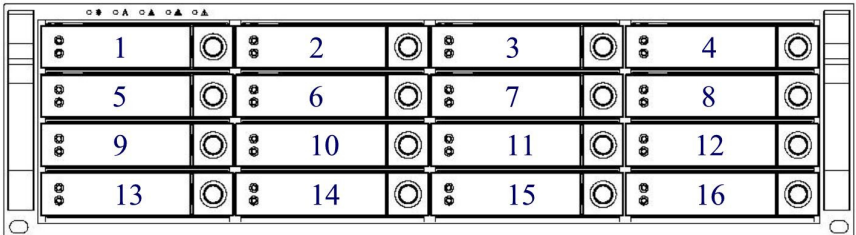

AS212X6R / AS212X6S

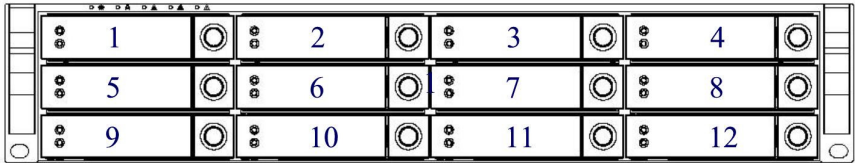

Drive Bay

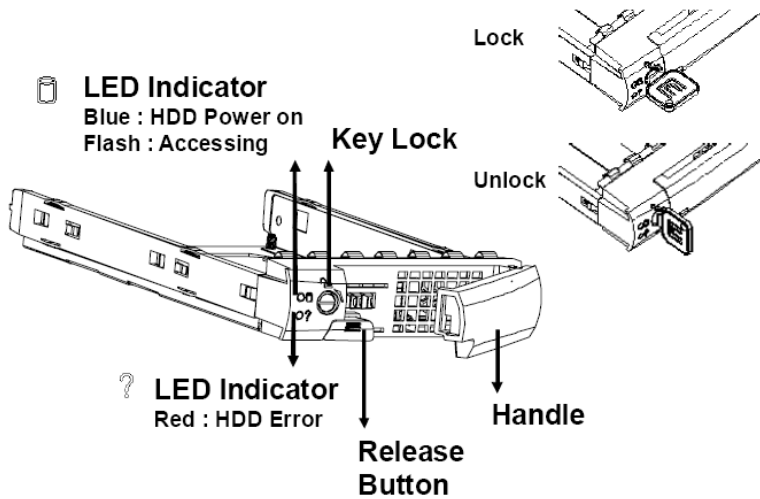

Rear Panel Overview

AS424X6S / AS424X6R 24bays SAS to SAS/SATA JBOD SUBSYSTEM

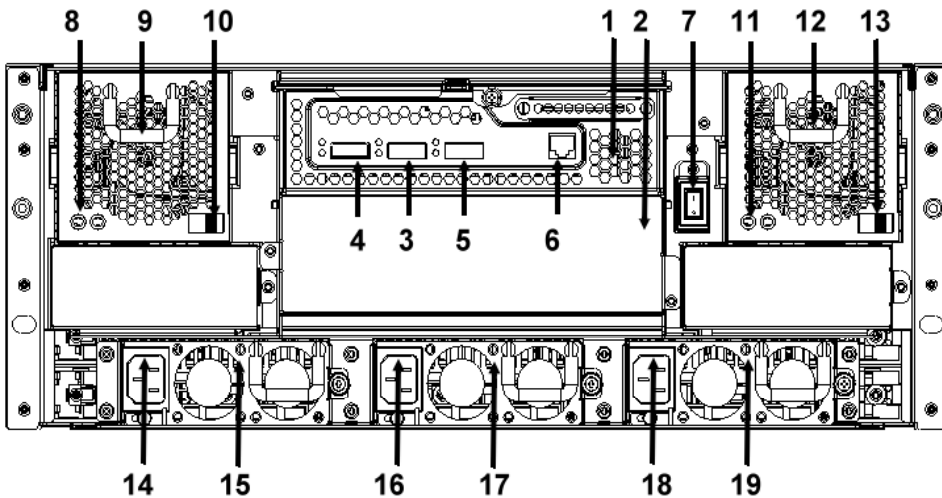

1. Expander Controller Box 1.
2. Expander Controller Box 2
3. SAS CH 0 & LED Indicator
4. SAS CH1 / Expand Port 1 & LED Indicator

LED	Colors	Indicate
SAS	Green	Link
	Blue + Blink	Access

5. SAS Expand Port 0 & LED Indicator

LED	Colors	Indicate
SAS	Green	Link
	Blue + Blink	Access

6. Console
7. Power Switch
8. FAN failure indicator (Rear / Front)
9. FAN Module 1
10. FAN Module 1 latch
11. FAN failure indicator (Rear / Front)
12. FAN Module 2
13. FAN Module 2 latch
14. AC inlet 1 & Latch
15. Power Module 1
16. AC inlet 2 & Latch
17. Power Module 2
18. AC inlet 3 & Latch
19. Power Module 3

AS316X6S / AS316X6R 16bays SAS to SAS/SATA JBOD SUBSYSTEM

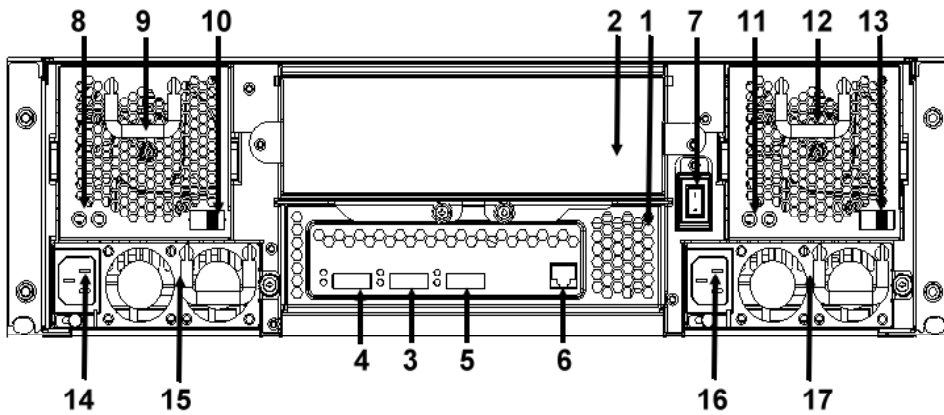

1. Expander Controller Box 1.
2. Expander Controller Box 2
3. SAS CH 0 & LED Indicator
4. SAS CH 1 & Expand Port 1 & LED Indicator

LED	Colors	Indicate
SAS	Green	Link
	Blue + Blink	Access

5. SAS Expand Port 0 & LED Indicator

LED	Colors	Indicate
SAS	Green	Link
	Blue + Blink	Access

6. Console
7. Power Switch
8. FAN failure indicator (Rear / Front)
9. FAN Module 1
10. FAN Module 1 latch
11. FAN failure indicator (Rear / Front)
12. FAN Module 2
13. FAN Module 2 latch
14. AC inlet 1 & Latch

- 15. Power Module 1
- 16. AC inlet 2 & Latch
- 17. Power Module 2

AS212X6S / AS212X6R 12bays SAS to SAS/SATA JBOD SUBSYSTEM

- 1. Controller Expander Box 1.
- 3. SAS CH 0 & LED Indicator
- 4. SAS CH 1 & Expand Port 1 & LED Indicator

LED	Colors	Indicate
SAS	Green	Link
	Blue + Blink	Access

- 5. SAS Expand Port 0 & LED Indicator

LED	Colors	Indicate
SAS	Green	Link
	Blue + Blink	Access

- 6. Console
- 7. Power Switch
- 8. Power Module 1
- 9. AC inlet 1 & Latch
- 10. Power Module 2
- 11. AC inlet 2 & Latch
- 12. FAN Module
- 13. FAN failure indicator (Rear / Front)
- 14. FAN Module Latch

Chapter 2. INSTALLATION

This chapter presents:

- ⇒ **Instructions on unpacking & checking the equipment**
- ⇒ **Instructions on how to install Hard disk drive**
- ⇒ **Instructions on how to install AccuSTOR JBOD in a Rack.**
- ⇒ **Instructions on how to connect AccuSTOR JBOD.**

Unpacking & checking the Equipment

Before unpacking the AccuSTOR JBOD subsystem, prepare a clean, stable surface to put on the contents of AccuSTOR 8 JBOD shipping container. Altogether, you should find following items in the package:

AccuSTOR, SAS to SAS/SATA JBOD Subsystem :

- . AccuSTOR JBOD subsystem x1
- . CD-ROM x 1 (Includes Hardware Installation Guide).
- . Serial cable x1
- . Power Cord x 2 (AS316X6S / AS316X6R and AS212X6S / AS212X6R), Power Cord x 3 (AS424X6S / AS424X6R)
- . SAS cable (SFF-8088) x 1
- . Spare Fan x 1
- . Drive Bay, (AS212X6S / AS212X6R x 12, AS316X6S / AS316X6R x 16, AS424X6S / AS424X6R x 24)
- . Rails for Rack
- . Mounting screws (bag) x1

What else you need

- Hard disk drives (different RAID levels requires different numbers of HDDs. Refer to Software Operation manual for more detail information.
- Host computer with SAS interface or AccuSTOR SAS RAID subsystem.
- Dedicated terminal or PC with third party communication software that supports ANSI terminal emulation (required for viewing Monitor Utility)

ESD Precaution

Use a suitable anti-static wrist or ankle strap and observe all conventional ESD precaution when handle AccuSTOR JBOD's modules and components. Avoid contact with backplane components and module connectors.

Installing hard disks

The AccuSTOR RAID series includes 16 hot swappable drive bays. The following sections describe how to install disks into AccuSTOR RAID subsystems.

Loading Hard Disk to the drive bay.

1. Put HDD into the bay.
2. Fasten all 4 screws to mount HDD in the bay and make sure the HDD is properly tightened.

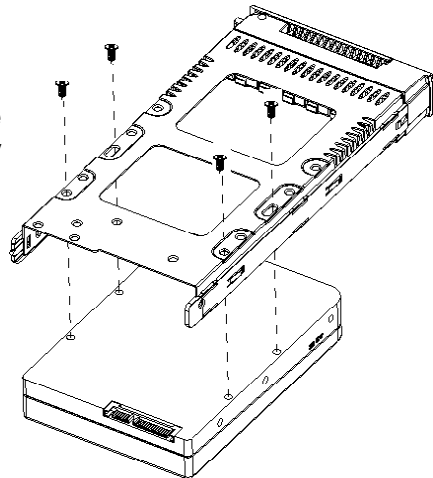

Place drive bays back into the system

1. Slide in drive bay, make sure the handle is open fully.
2. Close the handle to engage the drive bay into the slot.

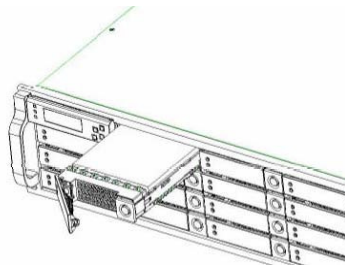



Note

The hard drives in a JBOD should match in size and speed. All drives in any array should be identical models with the same firmware versions.



Caution

Only use the screws offered with AccuSTOR RAID subsystem. Longer screws might cause the drive damage.

All the drive bays (with or without hard drive) must be placed in the AccuSTOR subsystem. AccuSTOR's cooling system is designed with full of drive bays. Missing drive bays might cause the subsystem damage.

Install The AccuSTOR JBOD subsystem in a Rack

You are shipped one rackmounting kit for each AccuSTOR subsystem that you intend to rackmount. AccuSTOR subsystem is designed for installation into a industry-standard 19-inch rackmount cabinet. Following the use of this section for installing the AccuSTOR subsystem into a Rack

Install the Slide Rails

1. Combine Left slide rail and rear slide rail.
2. Measure the depth of the rack enclosure, then fasten 4 of P4*8M screws into M4 Locking nuts to fix the length.
3. Use T5*8M screws and PW14 washer to install the left slide on Front and rear Posts of Rack as Figure 1.
4. repeat procedure 1 ~ 3 to install the right Slide into the Rack.

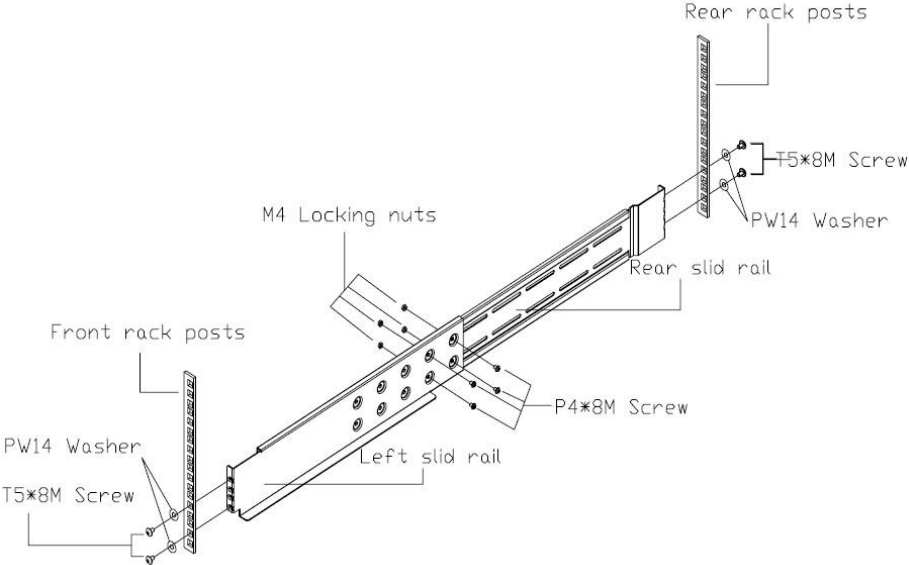

Figure 1.

Place the AccuSTOR Subsystem into the rack

- 1. Lift the subsystem enclosure and slide it slowly and gently along the slide rail into the rack as Figure 2.

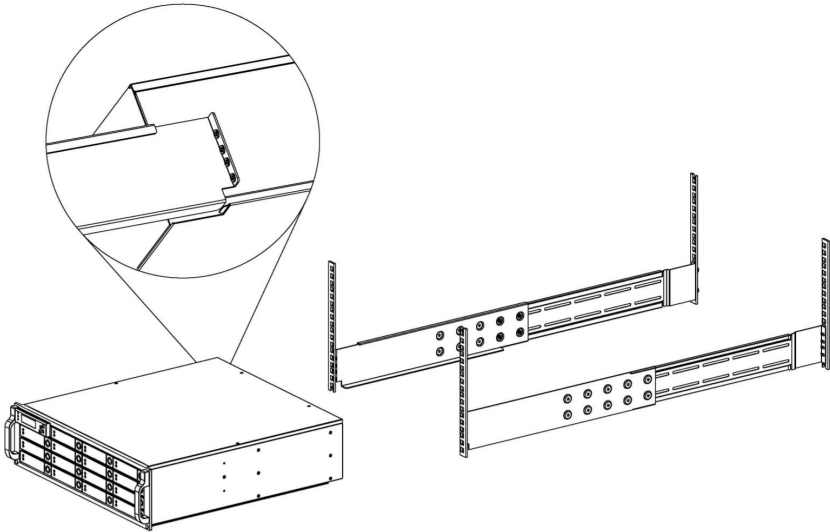

Figure 2.

2. Fasten two M5 screws through the chassis ears in the front side of the chassis to secure the AccuSTOR subsystem in the rack as Figure 3.

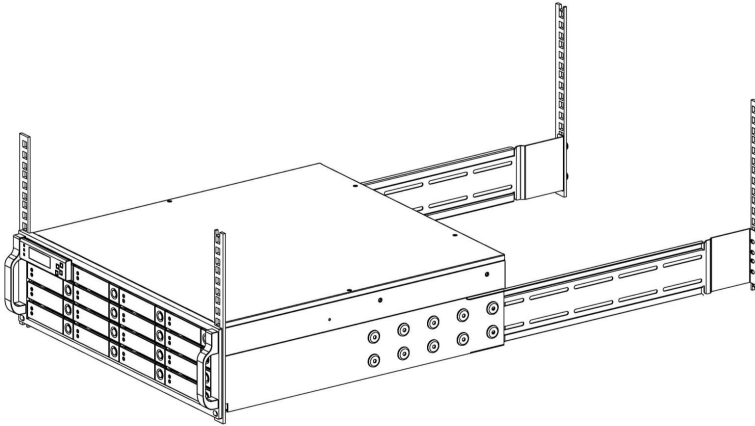

Figure 3.



Caution

Caution

The AccuSTOR subsystem is heavy, two person are required to move the system in the procedure.

System Connection

Connect all cables and power cord as shown below :

Cable	AccuSTOR JBOD	Device	Purpose
Serial Cable	Terminal Port	ANSI Terminal or a PC with Terminal emulator.	Configuration Utility
Mini SAS Cable	SAS CH0	SAS HBA of Host computer AccuSTOR SAS RAID subsystem	Host interface between JBOD and Host computer
Power Cord	Power inlet	A/C power outlet	A/C power input
Mini SAS Cable	SAS Exp.	AccuSTOR JBOD	Connect to SAS Expander



NOTE

Note

Make sure that all the devices are powered off before connecting or removing cables to prevent power spikes which can damage technical components.

Connection to the RAID System (Basic)

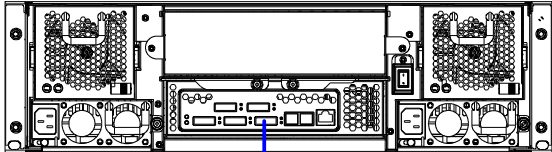

**16 Bay SAS-SAS
RAID Subsystem**

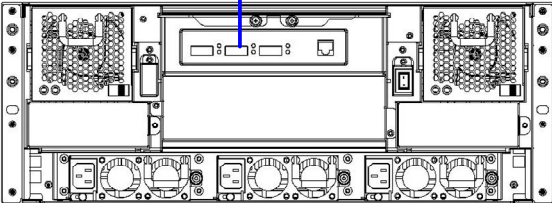

**24 Bay
SAS JBOD**

Connection to the RAID System with more SAS JBODs

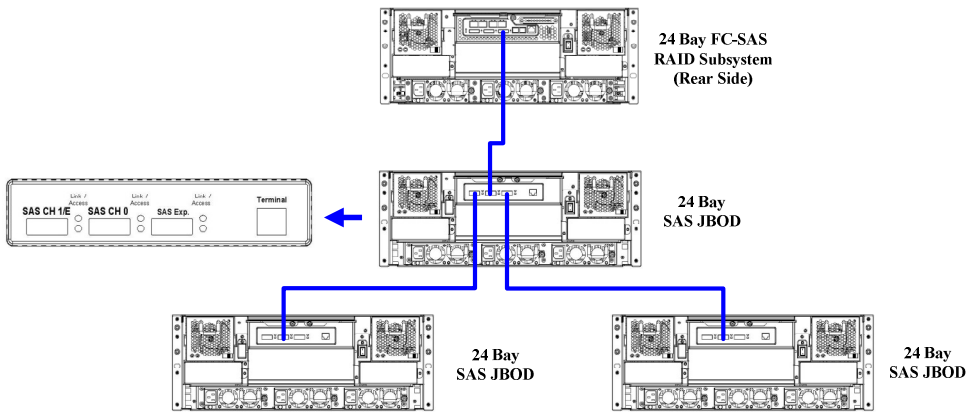

- ◆ **One Volume Set supports up to 32 HDDs**
- ◆ **One SAS Raid subsystem supports up to 128 Volumes**
- ◆ **One SAS Raid subsystem supports up to 122 HDDs**

There are three tiers within JBOD topology as above:

- First tier is a RAID System.
- Second tier is a SAS JBOD with a SAS CH0 on it. Connecting SAS CH0 to SAS exp. Port on RAID System via a Mini SAS to Mini SAS Cable.
- Third tier could be two SAS JBODs with a SAS CH0 port individually. One is connected to the SAS EXP. Port on the second tier SAS JBOD via a Mini SAS to Mini SAS Cable. Another is connected to the SAS CH1/E Port on the second tier SAS JBOD
- Fourth tier is a SAS JBOD with a SAS CH0 on it. Connecting SAS CH0 to SAS exp. Port on third tier SAS JBOD via a Mini SAS to Mini SAS Cable.

**NOTE**

1. *AccuSTOR RAID subsystem do not require the installation of different drivers for use with different operating systems. AccuSTOR RAID is independent and transparent to the host operating system.*
 2. *It is often recommended to install the hard drive with same brand, model no., interface and capacity in this RAID subsystem.*
 3. *Please do not install SAS and SATA hard drives at the same time, as these hard drives spin at different speed and may lead to compatible issues or performance decline.*
 4. *RAID members need to be included at the same enclosure that means you need to create array in the same enclosure. RAID members across two or more enclosures would get some risks (for example: if mini-SAS cable get problem, more RAID members will be lost, volume sets belong to this Array may be failed. Shutdown RAID and JBOD to fix problem, after that, turn on JBOD and RAID system again and controller will get array back, but in some special case maybe it can't get array back)*
-

Turning on for the first time

When cabling is completed, SAS RAID system + SAS JBOD system can be turned on. This should be done in the following order:

1. First turn on the power switch of “SAS JBOD” system.
2. Then turn on the power switch of “SAS RAID” system
3. Power on and boot the host computer(s)

Turning off

When turning off SAS RAID system + SAS JBOD system, users are advised to first shut down the server, then power off SAS RAID SYSTEM ,finally power off SAS JBOD SYSTEM.

Chapter 3. TROUBLE SHOOTING

This chapter contains trouble shooting procedures and suggestions to minimize their impact on the AccuSTOR JBOD operation :

⇒ **Instructions on how to replace the components of AccuSTOR JBOD subsystem.**

If the fault LED on the front panel of AccuSTOR JBOD lights , or if AccuSTOR RAID's Internet manager indicates a fault of JBOD, determine the reason for this alert immediately. Examine the component LEDs to see if any indicates a fault, then replace it as soon as possible.

Replace the Expander box



Caution

Read the replacing notices earlier in this chapter before proceeding with replacement.

This section provides instructions for the removal and installation of the Expander box components indicated in the figure below. This section is for the reference of engineers. End users should not need to replace or remove components.

Removing the Expander box from AccuSTOR JBOD :

In order to access expander box,

- 1.1 Disconnect all cables.
- 1.2 turn anti-clock wise to release two thumb screws.
- 1.3 use the eject bar to remove expander box.

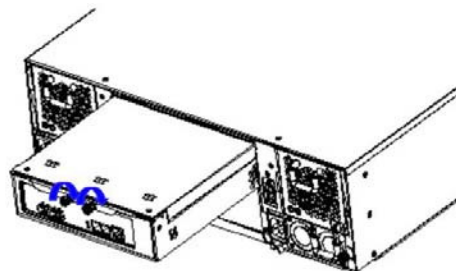

Installing the controller into AccuSTOR JBOD:

Reverse the procedure of “**removing the expander box**” to install the expander box

Hot Swapping to replace the Fan Module

This section provides instructions for the removal and installation of the Fan Module indicated in the figure below.

Removing the Fan Module from AccuSTOR :

Remove the Fan modules by slide the release button left and pull the module out of system.

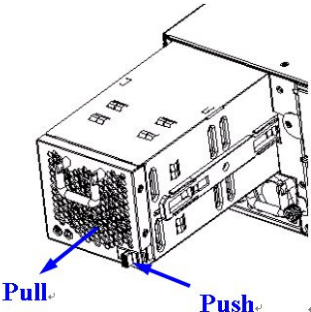

Installing the Fan module into AccuSTOR : Insert a Fan module.

Replace the Fan in Fan module

1. There are two failure LEDs on the rear of Fan module. Check which LED lights to yellow.
2. Anti-clock wise to release the thumb screw .

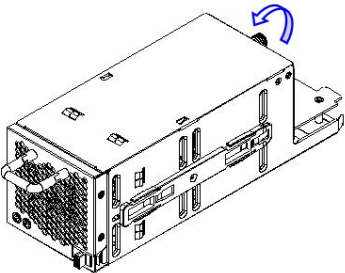

3. Slide the cover to blue arrow direction.

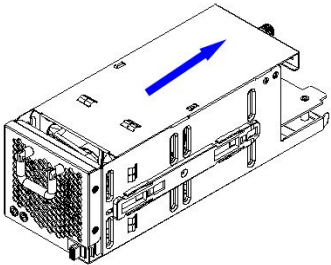

4. Remove the cover of Fan module and lift the Fans.

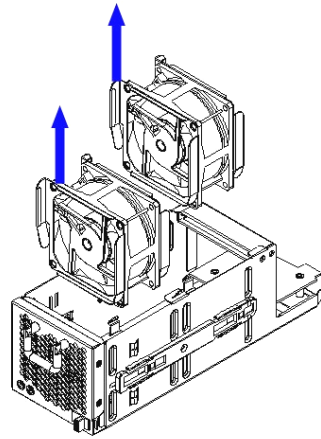

Hot Swapping to replace the Power Module

This section provides instructions for the removal and installation of the Power Module indicated in the figure below.

Removing the Power Module from JBOD system AL-9161J / AL-9241J :

- 1 & 2 : Unscrew the fastener.
- 3 : Release the latch and hold it at unlock-position.
- 4 : Slide it back and lifting off.

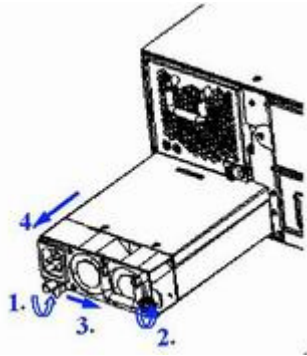

Removing the Power Module from JBOD system AL-9121J :

- 1 : Unscrew the fastener
- 2 : Slide it back and lifting off.

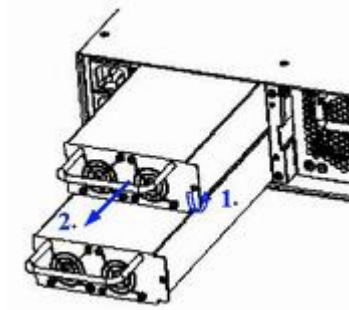

Installing the Power module into JBOD system :

Insert a Power module then fasten the screw.



The Power indicator will turn bright “Green” to indicate it has powered on

Appendix A. Connectors

RJ-11

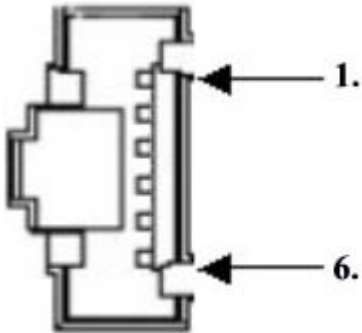

Pin#	Signal	Pin#	Signal
1	NC	6	NC
2	GND		
3	RX		
4	TX		
5	CTS		

miniSAS (SFF-8088)

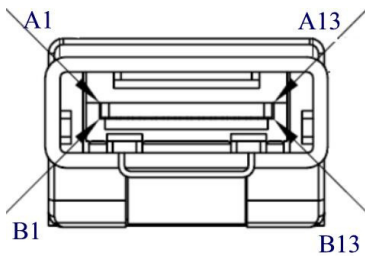

Pin#	Signal	Pin#	Signal
A1	GND	B1	GND
A2	RX0+	B2	TX0-
A3	RX0-	B3	TX0+
A4	GND	B4	GND
A5	RX1+	B5	TX1-
A6	RX1-	B6	TX1+
A7	GND	B7	GND
A8	RX2+	B8	TX2-
A9	RX2-	B9	TX2+
A10	GND	B10	GND
A11	RX3+	B11	TX3-
A12	RX3-	B12	TX3+
A13	GND	B13	GND

Appendix C.

Command Line Interface (CLI)

Create a CLI connection

The SAS JBOD has a **Command Line Interface (CLI)** to manage all of its functions, including customization. Access the CLI via your PC's terminal VT100 or ANSI emulation program, such as Microsoft HyperTerminal.

With the SAS JBOD running and the RS-232 cable connected to the Terminal port on SAS JBOD

1. open any UART communication tools like Hype Terminal

- Bits per second: 115200
- Data bits: 8
- Parity: None
- Stop bits: 1

2. press any key on HyperTerminal window, the window will show " Password : " prompt (Default Password :0000)

3. Enter Password, the window will show "CLI>" prompt

4. Type help will show help screen.

CLI Command Set

The CLI has the following commands:

HELP - Show All CLI commands and its usage

Usage: help

Example:

CLI>help

```
=====
Test          Command
```

```
=====
```

Set Password	pass
Logout CLI shell	lo
Link rate Control	link Index(D) High-Rate(D) Low-Rate(D) link
Temperature Control	th Index(D) High-Warn(D) Low-Warn(D) th
System Information	sys
Alarm Control	bu {mute [warning(D) critical(D)]} Bu
Fan Speed Control	fan LowestSpeed(D) WarningSpeed(D) fan
Drive SpinUp Control	spin Delay(D)[ms] Num(D) spin
Store System Setting	st
List Devices Status	lsd [hdd temp volt pwr con ..]
Resets the expander	reset watchdog(optional)
Route Table Read	rtr Display[(Default)/d/z/dz] Default display enabled entries with a nonzero SAS address d include disabled entries z include entries with a zero SAS address

	dz display all entries
Show the current logs	showlogs DisplayMode(hex, detail, default)
Clear the logs	clearlogs
Add string to the log	log "string"
File DownLoad	fdl { code mfgb ..} Buffer-Offset(H) Erase[Y(Default)/ N]
Display Info for all phys	phyinfo Help[?]
Display/Reset all phy counters	counters reset(optional)
Display expander SAS address	sasaddr
CLI Help	help command

=====

Pass - Set Password

Usage: pass (Max. 8 chars, Min. 4 chars)

Example:

```
CLI>pass
Old Password:****
New Password:****
verify new Password:****
Update Successfully But Not Save Permanently!
```

LO - Logout CLI shell

Usage: lo

Example:

CLI>lo

 Password:

LINK - Link rate Control

Usage: link

Example:

CLI>link

 ArrayDevice Element (0x17):

```
=====
```

NAME	PHY	NLR	MAX	MIN	TYPE	ADDRESS
SLOT 01	7	6.0G	10	8	SAS	5000C500-103F7AA5
SLOT 02	6	6.0G	10	8	SAS	5000C500-10439631
SLOT 03	11	6.0G	10	8	SAS	5000C500-10438DFD
SLOT 04	10	6.0G	10	8	SATA	5001B4D5-060E700A
SLOT 05	3	6.0G	10	8	SATA	5001B4D5-060E7003
SLOT 06	4	6.0G	10	8	SATA	5001B4D5-060E7004
SLOT 07	12	6.0G	10	8	SATA	5001B4D5-060E700C
SLOT 08	14	6.0G	10	8	SATA	5001B4D5-060E700E
SLOT 09	1	6.0G	10	8	SATA	5001B4D5-060E7001
SLOT 10	2		10	8		
SLOT 11	13		10	8		
SLOT 12	15		10	8		
SLOT 13	5		10	8		
SLOT 14	0		10	8		
SLOT 15	8		10	8		
SLOT 16	9		10	8		

TH - Operate the Thermal Attribute

Usage: th

Example:

```
CLI>th
```

```
Temperature Element (0x04):
```

```
=====
NAME          ID  CT('C)  HTW    LTW  OTWarn
ENC. Temp     01  27      60     5   No
Chip Temp     02  53      85     5   No
Slot01 Temp   03  26      60     5   No
Slot02 Temp   04  28      60     5   No
Slot03 Temp   05  27      60     5   No
Slot04 Temp   06  NA      60     5   No
Slot05 Temp   07  NA      60     5   No
Slot06 Temp   08  NA      60     5   No
Slot07 Temp   09  NA      60     5   No
Slot08 Temp   10  NA      60     5   No
Slot09 Temp   11  NA      60     5   No
Slot10 Temp   12  NA      60     5   No
Slot11 Temp   13  NA      60     5   No
Slot12 Temp   14  NA      60     5   No
Slot13 Temp   15  NA      60     5   No
Slot14 Temp   16  NA      60     5   No
Slot15 Temp   17  NA      60     5   No
Slot16 Temp   18  NA      60     5   No
```

SYS - Print System Information

Usage: sys

Example:

```
CLI>sys
```

```
=====
Hardware Revision Information:-
=====
Vendor ID          :
Model ID           : 8016
```

Serial No. : 8888888888888888
Unit Serial No. :
Expander SAS Address : 0x5001B4D5060E703F
Product Revision : 0
Expander Chip ID : 0x0221 (Ports : 28)
Expander Chip Revision : B3
Customer Code : 0x2
Manufacturer Data Revision : 0x05
Working Time : Day00000-00:22:03

=====
Firmware Revision Information:-

=====
Active Firmware: Active Image

Boot Image:
Revision: 7.B0.02.8F 11/15/10
Firmware Family: 1 OemFamily: 0
Fast Boot: No Image Address: 0x14000000

Active Image:
Revision: 7.B0.02.8F 11/15/10
Firmware Family: 1 OemFamily: 0
Fast Boot: No Image Address: 0x14080000

Backup Image:
Revision: 7.B0.02.8F 11/15/10
Firmware Family: 1 OemFamily: 0
Fast Boot: No Image Address: 0x14100000

HAL Revision: 0.7.0.0 SES Revision: 0.7.0.0 SCE Revision: 0.7.0.0

BU - Operate the Buzzer Attribute

Usage: bu [MUTE]**Example:**

```
CLI>bu
```

```
AudibleAlarm Element (0x06):
```

```
=====
NAME          STATUS  ALMSTATE
Audible-Alarm Normal   0
```

```
Current Alarm Attribute:
```

```
Warning Alarm: Sound2
```

```
Critical Alarm: Sound3
```

```
CLI>
```

```
turn off buzzer
```

```
CLI>bu mute
```

```
Alarm beep Muted
```

```
CLI>
```

FAN - Operate the Fan Attribute**Usage : fan****Example:**

```
CLI>fan
```

```
Cooling Element (0x03):
```

```
=====
SPEED
NAME  CODE  RPM  STATUS
Fan 01   5   3800  OK
Fan 02   5   3870  OK
Fan 03   5   3870  OK
Fan 04   5   3870  OK
```

Saved FAN Speed Attribute:

Lowest SpeedCode: 5

Warning SpeedCode: 7

ST - Store System Setting

Usage: st

Example:

CLI>st

ALL Of The User Configurations are Saved.

CLI>

LSD – List Devices Status

Usage: lsd

Example:

CLI>lsd

Show SES elements information

ArrayDevice Element (0x17):

```
=====
```

NAME	PHY	NLR	MAX	MIN	TYPE	ADDRESS
SLOT 01	7	6.0G	10	8	SAS	5000C500-103F7AA5
SLOT 02	6	6.0G	10	8	SAS	5000C500-10439631
SLOT 03	11	6.0G	10	8	SAS	5000C500-10438DFD
SLOT 04	10	6.0G	10	8	SATA	5001B4D5-060E700A
SLOT 05	3	6.0G	10	8	SATA	5001B4D5-060E7003
SLOT 06	4	6.0G	10	8	SATA	5001B4D5-060E7004
SLOT 07	12	6.0G	10	8	SATA	5001B4D5-060E700C
SLOT 08	14	6.0G	10	8	SATA	5001B4D5-060E700E
SLOT 09	1	6.0G	10	8	SATA	5001B4D5-060E7001
SLOT 10	2		10	8		
SLOT 11	13		10	8		

SLOT 12	15	10	8
SLOT 13	5	10	8
SLOT 14	0	10	8
SLOT 15	8	10	8
SLOT 16	9	10	8

Connector Element (0x19):

```
=====
```

NAME	PHY	NLR	TYPE	ROUTE	CONNECTED-ADDRESS
Connector00	24	02			
Connector00	25	02			
Connector00	26	02			
Connector00	27	02			
Connector01	20	6.0G 02	S		5001B4D5-0163B03F
Connector01	21	6.0G 02	S		5001B4D5-0163B03F
Connector01	22	6.0G 02	S		5001B4D5-0163B03F
Connector01	23	6.0G 02	S		5001B4D5-0163B03F
Connector02	16	02			
Connector02	17	02			
Connector02	18	02			
Connector02	19	02			

Cooling Element (0x03):

```
=====
```

SPEED

NAME	CODE	RPM	STATUS
Fan 01	5	3800	OK
Fan 02	5	3870	OK
Fan 03	5	3870	OK
Fan 04	5	3870	OK

Temperature Element (0x04):

```
=====
```

NAME	ID	CT('C)	HTW	LTW	OTWarn
ENC. Temp	01	27	60	5	No
Chip Temp	02	37	85	5	No
Slot01 Temp	03	27	60	5	No
Slot02 Temp	04	28	60	5	No
Slot03 Temp	05	27	60	5	No
Slot04 Temp	06	27	60	5	No
Slot05 Temp	07	27	60	5	No
Slot06 Temp	08	27	60	5	No
Slot07 Temp	09	27	60	5	No
Slot08 Temp	10	27	60	5	No
Slot09 Temp	11	26	60	5	No
Slot10 Temp	12	NA	60	5	No
Slot11 Temp	13	NA	60	5	No
Slot12 Temp	14	NA	60	5	No
Slot13 Temp	15	NA	60	5	No
Slot14 Temp	16	NA	60	5	No
Slot15 Temp	17	NA	60	5	No
Slot16 Temp	18	NA	60	5	No

Voltage Element (0x12):

```
=====
```

NAME	VOLT(V)	OVLMT	UVLMT	STATUS
1V	0.97	1.07	0.94	None
5V	5.04	5.32	4.63	None
3.3V	3.21	3.53	3.05	None
12V	11.92	12.80	11.12	None

PowerSupply Element (0x02):

```
=====
```

NAME	STATUS
PowerSupply01	OK
PowerSupply02	OK

AudibleAlarm Element (0x06):

```
=====
NAME          STATUS  ALMSTATE
Audible-Alarm Normal   None
CLI>
```

RESET - System Software Reset

Usage: reset → Reset SAS JBOD

SHOWLOGS - Print System Log.

Usage: showlogs

CLEARLOGS - Print System Log.

Usage: showlogs

FDL - File DownLoad

Usage: fdl { code | mfgb } offset → Upgrade F/W command

Then use XModem/(Checksum) protocol transmit file to update ROM Region

Appendix D. Specifications

Specifications

Model	AL-9241J	AL-9161J	AL-9121J
System Type	4U Rackmount	3U Rackmount	2U Rackmount
Expander numbers	1 or 2	1 or 2	1
Host Interface	Single minSAS connectors (4 x 6Gb Links) / Expander		
Host Transfer Rate	6Gb/ Sec		
Disk Interface	SAS 6.0 Gbps/ Port 2 x minSAS for Expansion		
Disk Channel	24 x SAS 6.0Gb/6.0GSATA	16x SAS 6.0Gb/6.0 GbSATA	12 x SAS 3.0Gb/6.0 Gb SATA
Hot Swap and redundant	Yes (Power Supply, Drive and Fan).		
Hot Spare	Yes (Drive).		
Monitoring / Indicators	Through In-band SES (SCSI Enclosure Service) LED Indicators on Front Panel		
Remote Terminal Configuration	Yes.		
Operating Systems	O/S Independent and Transparent		
Power Supply	460+460+460 watts Redundancy high quality power system, Three 460 watts module with PFC function. Load sharing type and cable-less design with Redundancy Three Power inlet	460+460 watts Redundancy high quality power system, two 460 watts module with PFC function. Load sharing type and cable-less design with Redundancy Dual Power inlet	375+375 watts Redundancy high quality power system, two 375 watts module with PFC function. Load sharing type and cableless design with Redundancy Dual Power inlet
Electrical	AC Voltage 100-240 VAC Ac Frequency 47-63Hz		
Temperature	Operating Temperature : 5 to 35 degree C. Non Operating Temperature : -40 to 60 degree C.		
Relative Humidity	20% to 80% non-condensing		
Dimensions	446.5mm(W)*550mm(D)*4U	446.5mm(W)*550mm(D)*3U	446.5mm(W)*527mm(D)*2U



NOTE

Specifications subject to change without notice.